

# BD 500 Beta - Condenser Boundary Layer Microphone

EN

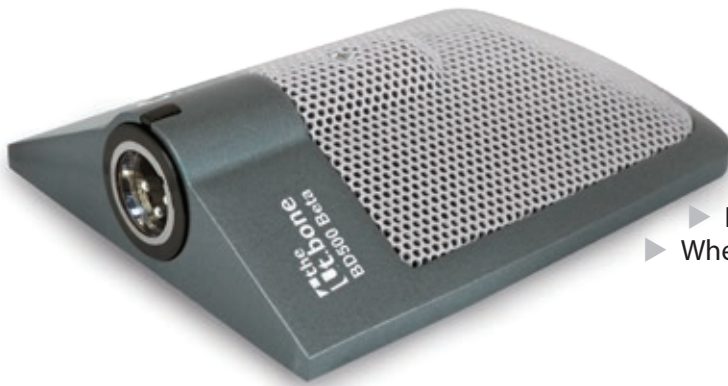

### Caution!

- ▶ Never drop the mic, as this may cause severe damage!
- ▶ When the microphone is not in use, take it out of its clamp and put it in its case. Clean with damp cloth only.

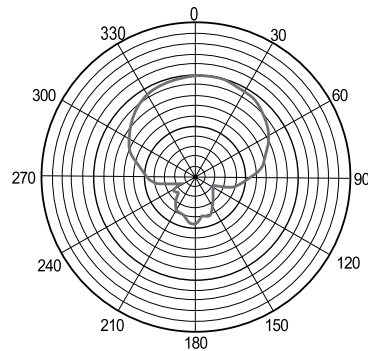
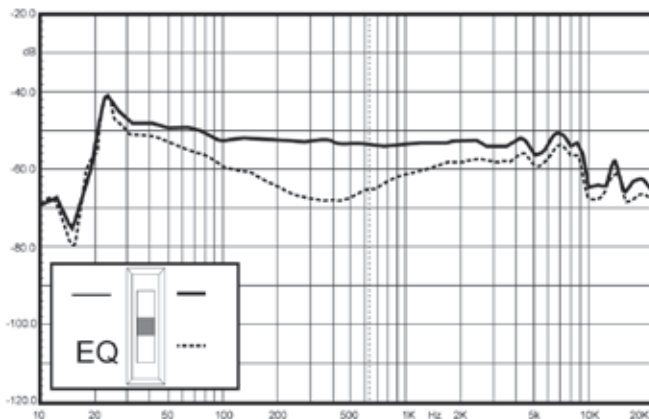

- ✓ Switchable frequency response for bass drum or piano / speech applications
- ✓ Robust metal housing
- ✓ Hanging holes at the back
- ✓ Underside with non-slip rubber for firmness and protection against surfaces



Polar pattern @ 1 kHz

Connection / Supply	XLR / P48
Transducer concept	Back electret condenser
Directivity	Half cardioid
Frequency response	30 - 20.000 Hz
Impedance	250 Ω ± 20 %
Sensitivity	-53 dB ± 3 dB (0 dB = 1 V/Pa, 1 kHz)
Maximum SPL	140 dB SPL @ 1 % THD
Dimensions	95 × 123 mm
Weight	480 g

 For the transport and protective packaging, environmentally friendly materials have been chosen that can be supplied to normal recycling. Ensure that plastic bags, packaging, etc. are properly disposed of. Do not just dispose of these materials with your normal household waste, but make sure that they are collected for recycling. Please follow the notes and markings on the packaging.

 This product is subject to the European Waste Electrical and Electronic Equipment Directive (WEEE) in its currently valid version. Do not dispose of your old device with your normal household waste.  Dispose of this product through an approved waste disposal firm or through your local waste facility. Comply with the rules and regulations that apply in your country. If in doubt, consult your local waste disposal facility.