



  
STAIRVILLE

Outdoor Stage PAR  
12 × 3W WLA  
LED PAR

Musikhaus Thomann  
Thomann GmbH  
Hans-Thomann-Straße 1  
96138 Burgebrach  
Germany  
Telephone: +49 (0) 9546 9223-0  
E-mail: [info@thomann.de](mailto:info@thomann.de)  
Internet: [www.thomann.de](http://www.thomann.de)

28.12.2018, ID: 405347 (V4)

# Table of contents

<b>1</b>	<b>General notes</b> .....	<b>5</b>
	1.1 Further information.....	6
	1.2 Notational conventions.....	7
	1.3 Symbols and signal words.....	7
<b>2</b>	<b>Safety instructions</b> .....	<b>10</b>
<b>3</b>	<b>Features</b> .....	<b>16</b>
<b>4</b>	<b>Installation</b> .....	<b>18</b>
<b>5</b>	<b>Starting up</b> .....	<b>23</b>
<b>6</b>	<b>Connections and operating elements</b> .....	<b>26</b>
<b>7</b>	<b>Operating</b> .....	<b>29</b>
	7.1 Starting the device.....	29
	7.2 Main menu.....	29
	7.3 Menu overview.....	36
	7.4 Functions in 3-channel DMX mode.....	37
	7.5 Functions in 5-channel DMX mode.....	37

7.6	Functions in 7-channel DMX mode.....	38
<b>8</b>	<b>Technical specifications.....</b>	<b>41</b>
<b>9</b>	<b>Plug and connection assignments.....</b>	<b>42</b>
<b>10</b>	<b>Troubleshooting.....</b>	<b>43</b>
<b>11</b>	<b>Cleaning.....</b>	<b>45</b>
<b>12</b>	<b>Protecting the environment.....</b>	<b>46</b>

# 1 General notes

This manual contains important instructions for the safe operation of the unit. Read and follow the safety instructions and all other instructions. Keep the manual for future reference. Make sure that it is available to all those using the device. If you sell the unit please make sure that the buyer also receives this manual.

Our products are subject to a process of continuous development. Thus, they are subject to change.

## 1.1 Further information

On our website ([www.thomann.de](http://www.thomann.de)) you will find lots of further information and details on the following points:

Download	This manual is also available as PDF file for you to download.
Keyword search	Use the search function in the electronic version to find the topics of interest for you quickly.
Online guides	Our online guides provide detailed information on technical basics and terms.
Personal consultation	For personal consultation please contact our technical hotline.
Service	If you have any problems with the device the customer service will gladly assist you.

## 1.2 Notational conventions

This manual uses the following notational conventions:

### Letterings

The letterings for connectors and controls are marked by square brackets and italics.

**Examples:** *[VOLUME]* control, *[Mono]* button.



### Displays

Texts and values displayed on the device are marked by quotation marks and italics.



**Examples:** *'24ch'*, *'OFF'*.

## 1.3 Symbols and signal words

In this section you will find an overview of the meaning of symbols and signal words that are used in this manual.

Signal word	Meaning
<b>DANGER!</b>	This combination of symbol and signal word indicates an immediate dangerous situation that will result in death or serious injury if it is not avoided.
<b>WARNING!</b>	This combination of symbol and signal word indicates a possible dangerous situation that can result in death or serious injury if it is not avoided.
<b>NOTICE!</b>	This combination of symbol and signal word indicates a possible dangerous situation that can result in material and environmental damage if it is not avoided.
Warning signs	Type of danger
	Warning – high-voltage.
	Warning – dangerous optical radiation.



Warning signs	Type of danger
	Warning – suspended load.
	Warning – danger zone.

## 2 Safety instructions

### Intended use

This device is intended for use as an electronic lighting effect by means of LED technology. The device is designed for professional use and is not suitable for use in households. Use the device only as described in this user manual. Any other use or use under other operating conditions is considered to be improper and may result in personal injury or property damage. No liability will be assumed for damages resulting from improper use.

This device may be used only by persons with sufficient physical, sensorial, and intellectual abilities and having corresponding knowledge and experience. Other persons may use this device only if they are supervised or instructed by a person who is responsible for their safety.

Extend the life of the device by regular breaks in operation and avoid switching it on and off frequently. This device is not suitable for continuous use.

**Safety****DANGER!****Danger for children**

Ensure that plastic bags, packaging, etc. are disposed of properly and are not within reach of babies and young children. Choking hazard!

Ensure that children do not detach any small parts (e.g. knobs or the like) from the unit. They could swallow the pieces and choke!

Never let children unattended use electrical devices.

**DANGER!****Electric shock caused by high voltages inside**

Within the device there are areas where high voltages may be present. Never remove any covers.

There are no user-serviceable parts inside.

Do not use the device if covers, protectors or optical components are missing or damaged.



**DANGER!**

**Electric shock caused by short-circuit**

Do not modify the mains cable or the plug. Failure to do so could result in electric shock/death or fire. If in doubt, seek advice from a registered electrician.



**WARNING!**

**Eye damage caused by high light intensity**

Never look directly into the light source.



**WARNING!**

**Risk of epileptic shock**

Strobe lighting can trigger seizures in photosensitive epilepsy. Sensitive persons should avoid looking at strobe lights.



**NOTICE!**

**Risk of fire**

Do not block areas of ventilation. Do not install the device near any direct heat source. Keep the device away from naked flames.



### **NOTICE!**

#### **Operating conditions**

This device has been designed for indoor use only. To prevent damage, never expose the device to any liquid or moisture. Avoid direct sunlight, heavy dirt, and strong vibrations.

Only operate the device within the ambient conditions specified in the chapter 'Technical specifications' of this user manual. Avoid heavy temperature fluctuations and do not switch the device on immediately after it was exposed to temperature fluctuations (for example after transport at low outside temperatures).

Dust and dirt inside can damage the unit. When operated in harmful ambient conditions (dust, smoke, nicotine, fog, etc.), the unit should be maintained by qualified service personnel at regular intervals to prevent overheating and other malfunction.



**NOTICE!**

**Power supply**

Before connecting the device, ensure that the input voltage (AC outlet) matches the voltage rating of the device and that the AC outlet is protected by a residual current circuit breaker. Failure to do so could result in damage to the device and possibly injure the user.

Unplug the device before electrical storms occur and when it is unused for long periods of time to reduce the risk of electric shock or fire.

### 3 Features

Due to its sturdy and weather-proof housing made of die-cast aluminium, the Outdoor Stage PAR 12 × 3W WLA is specially designed for outdoor use.

Special features of the device:

- 12 × WLA LEDs (each 3 W)
- Control via DMX (three different modes) and via buttons and display on the unit
- seven preprogrammed automatic shows
- Master / Slave operation
- rugged die-cast aluminium housing
- IP65 (suitable for outdoor use)
- Splashproof safety plug (IP44)
- Pressure compensation element (prevents condensation inside the device)
- sturdy double bracket for secure attachment to trusses or firm footing on the ground



---

**Information about protection class IP65**

Equipment with protection class IP65 are dust-tight and completely protected against contact (first code number). They are also protected against splash water from any angle (second code digit). That is why this equipment can also be used outdoors. Event technology equipment is generally only designed for temporary use however (event lighting) and not for permanent use outdoors.

The specified protection class does not make a statement about the weather resistance of the equipment (resistance to changing ambient conditions as well as against the effects of sunlight and UV rays).

The seals and screw connections of the equipment must be checked regularly to ensure a fault-free operation. In cases of doubt, consult a specialist workshop in due time.

## 4 Installation

Unpack and check carefully there is no transportation damage before using the unit. Keep the equipment packaging. To fully protect the product against vibration, dust and moisture during transportation or storage use the original packaging or your own packaging material suitable for transport or storage, respectively.



**WARNING!**

**Risk of injury caused by falling objects**

Make sure that the installation complies with the standards and rules that apply in your country. Always secure the device with a secondary safety attachment, such as a safety cable or a safety chain.



**NOTICE!**

**Risk of overheating**

Always ensure sufficient ventilation.

The ambient temperature must not exceed the limits stated in the chapter Technical Specifications of the User Manual.



**NOTICE!**

**Use of stands**

When mounting the device onto a stand, ensure that the stand is in a safe and stable position and that the weight of the device does not exceed the maximum permissible load capacity of the stand.



### **NOTICE!**

#### **Possible data transmission errors**

For error-free operation make use of dedicated DMX cables and do not use ordinary microphone cables.

Never connect the DMX input or output to audio devices such as mixers or amplifiers.



### **NOTICE!**

#### **Possible damage due to moisture**

Moisture entering into open connectors (plugs and couplers) of DMX or power cords can cause short circuits.

Close unused connectors with end caps intended for this purpose ([www.thomann.de](http://www.thomann.de)).

## Mounting options

You can install the unit in hanging or standing position. When in use, the device must always be attached to a solid surface or an approved truss. Benutzen Sie zur Befestigung die dafür vorgesehenen Öffnungen des zweiteiligen Bügels.

Always work from a stable platform whenever installing, moving or servicing the unit. In doing so, the area underneath the unit must be cordoned off.

The safety cable must be attached to the bracket.



*Please note that this device must not be connected to a dimmer.*

## Connecting the DMX IP65 connectors

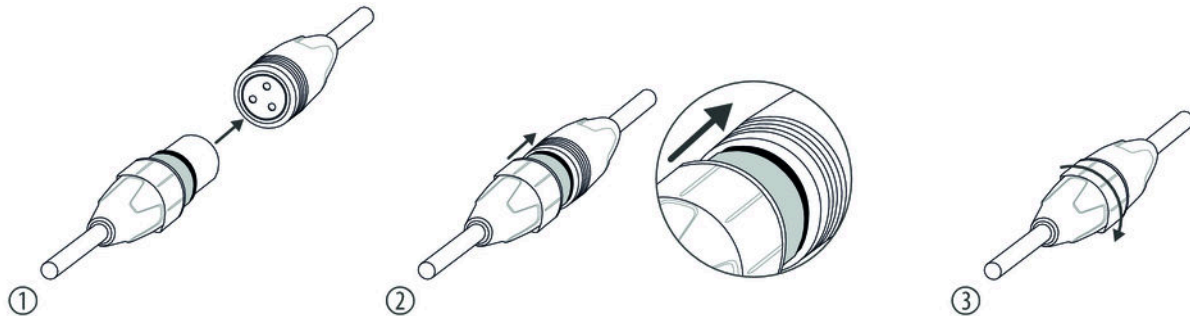

Proceed as follows to connect the DMX-IP65 connectors:

1. ➤ Insert the plug completely and straight into the coupling.
2. ➤ Make sure that the flexible sealing ring has complete contact.
3. ➤ Turn the union nut straight onto the thread of the coupling. Hand-tighten the union nut.

## 5 Starting up

Create all connections while the device is off. Use the shortest possible high-quality cables for all connections. Take care when running the cables to prevent tripping hazards.

### Connections in DMX mode

Connect the DMX input of the device to the DMX output of a DMX controller or another DMX device. Connect the output of the first DMX device to the input of the second one, and so on to form a daisy chain. Always ensure that the output of the last DMX device in the daisy chain is terminated with a resistor ( $110\ \Omega$ ,  $\frac{1}{4}\text{ W}$ ).

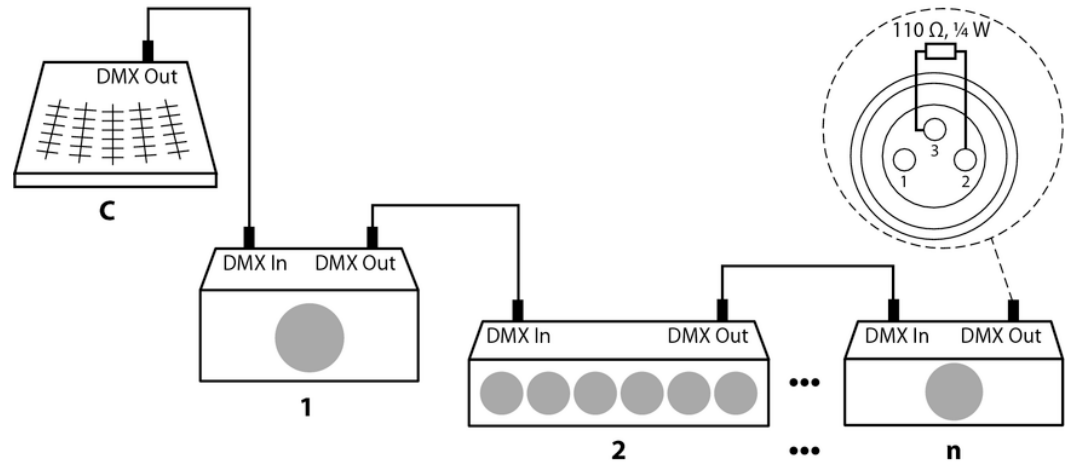



---

**Connections in 'Master / Slave' mode**

When you configure a group of devices in 'Master / Slave' mode, the first unit will control the others. This feature is especially useful to start a show without much programming. Connect the DMX output of the master unit to the DMX input of the first slave unit. Then connect the DMX output of the first slave unit to the DMX input of the second slave unit and so on.

## 6 Connections and operating elements

### Rear panel

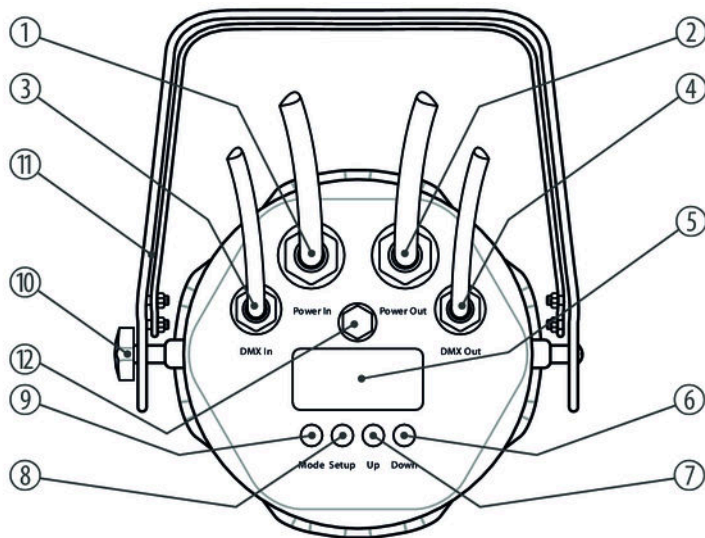

1	<i>[Power In]</i> Mains cable for the power supply of the device.
2	<i>[Power Out]</i> Power cord for the voltage supply of a connected device.
3	<i>[DMX IN]</i> DMX input cable
4	<i>[DMX OUT]</i> DMX output cable
5	Display
6	<i>[Down]</i> Decreases the displayed value by one.
7	<i>[Up]</i> Increases the displayed value by one.

8	<i>[Setup]</i> Selects an option of the respective operating mode.
9	<i>[Mode]</i> Activates the main menu and toggles between menu items.
10	Locking screws for the retaining bracket.
11	Retaining bracket
12	Pressure equalisation element

## 7 Operating

### 7.1 Starting the device

Connect the device to the power supply to start operation. After a few seconds, the display indicates that a reset is in progress. The device is then ready for use.

### 7.2 Main menu

Press *[Mode]* to activate the main menu and select an operating mode. Use *[Up]* and *[Down]* to change the respectively displayed value. When the display shows the desired value confirm with *[Setup]*. To return to the parent menu without making changes, press *[Mode]*.

If you don't press any button for about 20 seconds, the unit returns to the previously selected mode. The set values are retained even when the device is disconnected from the mains power supply.

### **Operating mode Auto**

In this mode, all preprogrammed shows are played consecutively in an endless loop. This setting is only relevant if the device is not controlled via DMX.

Use *[Mode]* to open the main menu. Press *[Up]* or *[Down]* repeatedly until the display shows 'Auto'. Confirm the selection with *[Setup]*.

### **Operating mode Show/Master**

In this mode, the device operates in stand-alone mode and can control connected devices of the same type. This setting is only relevant if the device is not controlled via DMX.

Use *[Mode]* to open the main menu. Press *[Up]* or *[Down]* repeatedly until the display shows 'Pr.xx'. Now you can select one of the seven preprogrammed automatic shows. Use *[Up]* and *[Down]* to select a value between 'Pr.01' and 'Pr.07'.

**Settings programme Pr.01**

For programme 'Pr.01' you have the choice between various static colours and colour mixtures based on the three basic colours amber, warm white and cold white. Select programme 'Pr.01' first, then confirm with 'Setup'. Now you can use the [Up] and [Down] buttons to select one of the following options:

Value	Description
'OFF'	all off
'--A'	Amber
'-AS'	Amber / warm white
'--S'	Warm white
'-AU'	Amber / cold white
'-SU'	Warm white / cold white
'--U'	Cold white
'ALL'	Amber / warm white / cold white

Confirm again with 'Setup'. In the following menu, you can use [UP] and [DOWN] to set the strobe frequency for the strobe effect individually in a range from 'FS00' to 'FS99'.

### **Settings programme Pr.02 ... Pr.07**

For programmes 'Pr.02' to 'Pr.01', you can set the programme speed and the flash frequency for the strobe effect after selecting the desired program.

First select the desired programme and confirm the selection with *[Setup]*.

Then use *[Up]* or *[Down]* to set the programme speed in a range from 'SP01' ... 'SPFL' (slow ... fast) and confirm with *[Setup]*.

Then use *[Up]* or *[Down]* to set the flash frequency for the strobe effect in a range from 'FS01' ... 'FS99' (slow ... fast) and confirm with *[Setup]*.



## Dimmer presets

In this menu, you can set the dimmer presets for the three basic colours of the unit.

Use *[Mode]* to open the main menu. Press *[Up]* or *[Down]* repeatedly until the display shows 'Colr'. Press *[Up]* or *[Down]* to consecutively set the dimmer presets for amber, warm white, and cold white as well as the flash frequency for the strobe effect. Confirm each value with *[Setup]* to get to the next value.

Value	Description
'A.000' ... 'A.255'	amber, intensity 0 % ... 100 %
'S.000' ... 'S.255'	warm white, intensity 0 % ... 100 %
'U.000' ... 'U.255'	cold white, intensity 0 % ... 100 %
'FS00' ... 'FS99'	Flash frequency for the strobe effect

## DMX mode

This setting is only relevant when the device is controlled via DMX.

Use *[Mode]* to open the main menu. Press *[Up]* or *[Down]* repeatedly until the display shows 'd.xxx'. Now you can set the number of the first DMX channel to be used by the device (DMX address). Use *[Up]* or *[Down]* to select a value between 1 and 510 (display shows 'd.001' ... 'd.510').

Make sure that this number matches the configuration of your DMX controller. The following table shows the highest possible DMX address for the various DMX modes.

Mode	Highest possible DMX address
3-channel	510
5-channel	508
7-channel	506

Confirm with *[Setup]*. Press *[Up]* or *[Down]* to select the desired DMX mode:

- '3-CH' (three channels)
- '5-CH' (five channels)
- '7-CH' (seven channels)

**Operating mode 'Slave'**

This setting is only relevant if the device is working as Slave in a Master / Slave configuration and is not controlled via DMX. In this operating mode, the device responds to the control signals of the master device.

Use *[Mode]* to open the main menu. Press *[Up]* or *[Down]* repeatedly until the display shows 'SLAV'. Confirm with *[Setup]*.

### 7.3 Menu overview

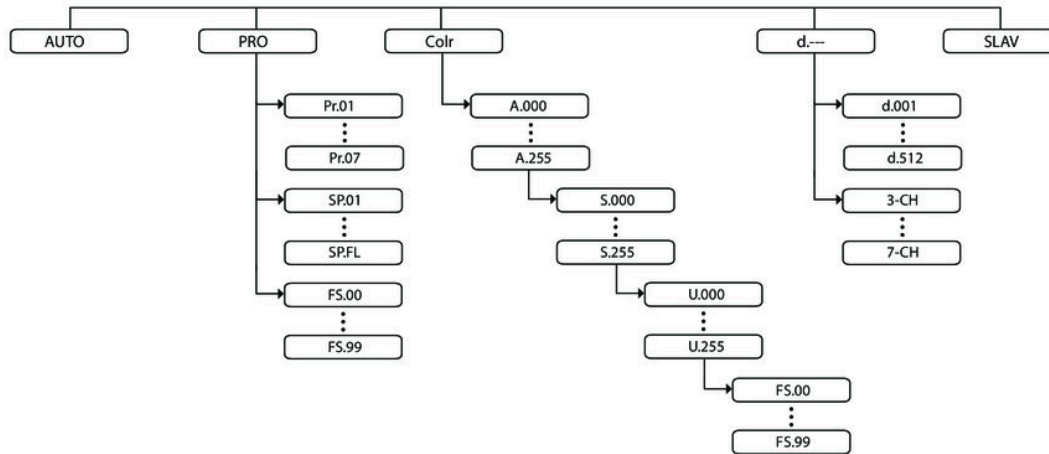

## 7.4 Functions in 3-channel DMX mode

Channel	Value	Function
1	0...255	Intensity amber (0 % to 100 %)
2	0...255	Intensity warm white (0 % to 100 %)
3	0...255	Intensity cold white (0 % to 100 %)

## 7.5 Functions in 5-channel DMX mode

Channel	Value	Function
1	0...255	Dimmer (0 % to 100 %)
2	0...255	Intensity amber (0 % to 100 %)
3	0...255	Intensity warm white (0 % to 100 %)

Channel	Value	Function
4	0...255	Intensity cold white (0 % to 100 %)
5	0...255	Stroboscope effect (0 % to 100 %)

## 7.6 Functions in 7-channel DMX mode

Channel	Value	Function
1	0...255	Dimmer (0 % to 100 %)
2	0...255	Intensity amber (0 % to 100 %)
3	0...255	Intensity warm white (0 % to 100 %)
4	0...255	Intensity cold white (0 % to 100 %)
5	Programme selection	
	0...35	Dimmer (0 % to 100 %)

Channel	Value	Function
	36...71	Programme 01
	72...107	Programme 02
	108...143	Programme 03
	144...179	Programme 04
	180...215	Programme 05
	216...251	Programme 06
	252...255	Programme 07
6	Macros (programme 1, if channel 5 = 36...71), process speed (programme 02 bis 07)	
	0...35	Blackout
	36...71	amber 255, warm white 0, cold white 0
	72...107	amber 255, warm white 255, cold white 0
	108...143	amber 0, warm white 255, cold white 0
	144...179	amber 255, warm white 0, cold white 255

Channel	Value	Function
	180...215	amber 0, warm white 255, cold white 255
	216...251	amber 0, warm white 0, cold white 255
	252...255	amber 255, warm white 255, cold white 255
7	0...255	Stroboscope effect (0 % to 100 %)



## 8 Technical specifications

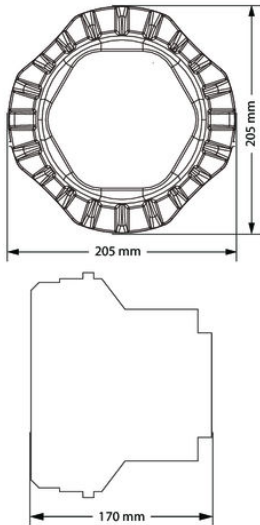

Illuminant	12 × WLA LEDs, each 3 W
Beam angle	30°
Number of DMX channels	3, 5, 7
Operating supply voltage	AC 100 – 240 V ~ 50/60 Hz
Power consumption	40 W
Protection class	IP65
Temperature range	-20 °C ... +45 °C
Dimensions (W × H × D)	205 mm × 205 mm × 170 mm
Weight	3.5 kg

Outdoor Stage PAR 12 × 3W WLA

## 9 Plug and connection assignments

### Introduction

This chapter will help you select the right cables and plugs to connect your valuable equipment so that a perfect light experience is guaranteed.

Please take our tips, because especially in 'Sound & Light' caution is indicated: Even if a plug fits into a socket, the result of an incorrect connection may be a destroyed DMX controller, a short circuit or 'just' a not working light show!

### DMX connections

The unit offers a 3-pin XLR socket for DMX output and a 3-pin XLR plug for DMX input. Please refer to the drawing and table below for the pin assignment of a suitable XLR plug.



Pin	Configuration
1	Ground, shielding
2	Signal inverted (DMX-, 'cold signal')
3	Signal (DMX+, 'hot signal')

## 10 Troubleshooting



### **NOTICE!**

#### **Possible data transmission errors**

For error-free operation make use of dedicated DMX cables and do not use ordinary microphone cables.

Never connect the DMX input or output to audio devices such as mixers or amplifiers.

In the following we list a few common problems that may occur during operation. We give you some suggestions for easy troubleshooting:

Symptom	Remedy
The unit does not work, no light.	Check the mains connection and the fuse.
No response to the DMX controller.	1. Check the DMX ports and cables for proper connection.
	2. Check the address settings and the DMX polarity.
	3. Try using another DMX controller.
	4. Check to see if the DMX cables run near or alongside to high voltage cables that may cause damage or interference to DMX interface circuits.

If the procedures recommended above do not succeed, please contact our Service Center. You can find the contact information at [www.thomann.de](http://www.thomann.de).

## 11 Cleaning

### Optical lenses

Clean the optical lenses, that are accessible from the outside, regularly in order to optimize the light output. The frequency of cleaning depends on the operating environment: wet, smoky or particularly dirty surroundings can cause more accumulation of dirt on the optics of the device.

- Clean with a soft cloth using our lamp and lens cleaner (item no. 280122).
- Always dry the parts carefully.

## 12 Protecting the environment

### Disposal of the packaging material



For the transport and protective packaging, environmentally friendly materials have been chosen that can be supplied to normal recycling.

Ensure that plastic bags, packaging, etc. are properly disposed of.

Do not just dispose of these materials with your normal household waste, but make sure that they are collected for recycling. Please follow the notes and markings on the packaging.

### Disposal of your old device



This product is subject to the European Waste Electrical and Electronic Equipment Directive (WEEE) in its currently valid version. Do not dispose with your normal household waste.

Dispose of this device through an approved waste disposal firm or through your local waste facility. When discarding the device, comply with the rules and regulations that apply in your country. If in doubt, consult your local waste disposal facility.



